

APPLYING AXIOMATIC DESIGN TO THE EDUCATIONAL PROCESS

Mary Kathryn Thompson.

mkt@kaist.edu

KAIST Department of Civil and
Environmental Engineering
373-1 Guseong-dong, Yuseong-gu,
Daejeon, 305-701, Korea

Benjamin C. Thomas

thomasb3@asme.org

2738 Ridgeview Rd
Powhatan VA, 23139
USA

Jonathan B. Hopkins

jhopkins@mit.edu

Massachusetts Institute of Technology
471 Memorial Drive 5-213
Cambridge MA 02139, USA

ABSTRACT

Axiomatic design theory (AD) was originally developed to form a scientific basis for mechanical design. This paper takes an in-depth look at axiomatic design theory as a scientific basis for the design of educational courses and curricula. The implications of the first and second axioms for education are discussed and issues associated with coupling, physical integration, repetition, redundancy, complexity, robustness, and flexibility are addressed.

Keywords: Axiomatic design, education, curriculum

1 INTRODUCTION

In *Axiomatic Design: Advances and Applications*, Suh [2001] states that “in the past, many engineers have designed their products (processes, systems, etc.) iteratively, empirically and intuitively, based on years of experience, cleverness or creativity, and involving much trial and error.” The same is still true for the design of educational courses or curricula. Although many attempts have been made to model the educational process and formalize methods for the design of courses and course materials, most of this work is still very qualitative and heavily based on experience or case studies.

Axiomatic design was originally developed to address this issue in mechanical design by providing a “scientific basis for design and to improve design activities by providing the designer with a theoretical foundation based on logical and rational thought processes and tools.” [Suh, 2001] This paper explores the potential of axiomatic design to provide a scientific basis for educational design. The implications of the first and second axioms for education are discussed and issues associated with coupling, physical integration, repetition, redundancy, complexity, robustness, and flexibility are addressed.

2 PRIOR ART

Much of the work that has been done in relating axiomatic design and education has focused on teaching students to use axiomatic design theory. However, very little has been done to explore the applicability and limitations of the theory in education.

In the course of our literature search, only two papers which used axiomatic design theory to develop educational courses were identified. The first paper is from Beijing Jiaotong University where Tate and Lu [2004] address the

need for teaching axiomatic design and use axiomatic design theory to design a course on axiomatic design. The second paper is also from Beijing Jiaotong University where Tate [2005] applies axiomatic design principles to an internet-based platform of teaching a course in mechanical design.

Both papers review the fundamentals of axiomatic design theory and use axiomatic design principles to develop educational courses to teach axiomatic design in the classroom and online. Many of the FR/DP pairs presented correlate closely with those identified in this paper and are well chosen. However, the focus is on using AD to teach AD. There is limited discussion of using AD for more general educational purposes. In addition, the methods presented take advantage of only the most basic aspects of AD and neglect some of the more powerful details. This work focuses on more general education and the implications and applicability of the first and second axioms to education.

3 DEFINING THE DESIGNER

In the realm of education, the designer may be the school board of directors, members of the school administration, or members of the teaching faculty. In home schooling, it might be the parents of the students. Because each of these groups of people has different responsibilities and different amounts of control, the functional requirements will be different for each. Thus, the choice of designer affects the scope of the design.

For this paper, we focus on the educator (teacher or professor) as the designer. This choice limits the discussion to the design of classes and curricula. It allows us to assume that funding, facilities, and the quantity and nature of students in the class or degree program are constraints, rather than design parameters, as they might be for members of the administration. Finally, it implies that the design will be executed by the designer, and not by a third party.

4 EDUCATION AND THE INDEPENDENCE AXIOM

4.1 DECOUPLED DESIGNS IN EDUCATION

Although the independence axiom requires that designs be uncoupled whenever possible, many educational applications are fundamentally decoupled. Just as children must learn to crawl before they can walk, students must learn the fundamentals of any given field before they can build on

necessary to satisfy a given FR. In both contexts, the emphasis is on “necessary.” There are three cases to consider when discussing repetition in axiomatic design for education: (1) repetition of a single DP for a single unsatisfied FR, (2) the use of multiple FR/DP pairs to cover the same topic, or (3) the repetition of a single DP to cover a previously satisfied FR.

The first case is only redundant if the DP is repeated more times than necessary. For example, consider the FR: “algorithmically train students to solve quadratic equations”, and the corresponding DP: “solve 10 homework problems on quadratic equations.” If the students actually need 20 homework problems to satisfy the FR, then the DP may be repeated without redundancy. However, if the DP is repeated again, thus assigning 30 homework problems when only 20 were needed, the case is redundant.

A mechanical analogy to this type of repetition can be seen in a machine that polishes silicon wafers. Multiple passes might be needed to achieve the desired finish, yet any single pass could not achieve the FR by itself. However, the notion of what is “necessary” is not absolute, but a function of the chosen DP. A different, more efficient polishing machine might achieve the desired finish in fewer passes, just as a more effective homework assignment might train the students in fewer problems if the specific problems are chosen wisely. It should be noted that efficiency, or a minimization of resources consumed, is not an intrinsic goal of AD, but it does appear in the FRs or constraints of nearly all design tasks, including education. Reducing repetition is favorable because it will reduce the consumption of time.

Education is not as straightforward as manufacturing because of the human factors involved. The number of repetitions required to polish a silicon wafer should not vary significantly from wafer to wafer, especially if the wafer supplier is constant over time. However, the number of homework problems required to train a student may vary substantially from student to student. This uncertainty and variability associated with the customer (the student) is one of the fundamental characteristics that distinguish a service industry like education from a manufacturing industry.

The second case: “the use of different DPs to achieve different FRs within the same topic,” is not redundant because a topic can be subdivided according to the required educational goals, and various orthogonal educational methods, or media. For example, consider the decomposition between domains in the general case below where we wish to design a curriculum to satisfy the customer attribute of “seeking graduates who are educated in topic i of subject x ” (Figure 1).

In order to educate students on the chosen topic, several different DPs (lecture, lab, reading, etc.) are used to present different aspects of the same material. But because each DP satisfies an independent FR, the design is not redundant.

The third case of repetition in education involves the repetition of a single DP to cover a previously satisfied FR. For example, consider the DP: “Give a lecture on topic A.”

This DP might have been used in the past to satisfy the FR: “Educate the students on topic A.” But if the same lecture on topic A is given as the DP for the FR: “Review topic A for students” the repetition is not redundant because the repeated DP is being used to satisfy a new FR of “refresh” or “maintain” the understanding of a topic. Instead, the design is coupled. Since this is not an improvement, a new DP: “Give a lecture to review key aspects of topic A” or “Give a review lecture with new examples of topic A” might be introduced to decouple the design.

In an ideal world, students would learn and remember everything perfectly the first time they are exposed to it. This would greatly increase the efficiency of the education process and reduce the time and resources required to teach each topic. Since we live in a non-ideal world where different students learn at different paces and in different ways, we should strive to only use repetition as much as necessary and no more.

4.5 FLEXIBLE SYSTEMS IN EDUCATION

The customers in service industries are a major source of uncertainty that is difficult to control. Education is no exception, especially at higher levels of education where students have a more freedom in choosing their courses. There can be many students to be educated, and many topics in which to educate them, yet specific combinations of students and topics can change continuously and unpredictably. Curricula must then have the ability to reconfigure. Each student is a customer, so as new students enter and pass through the system, the customer attributes will change, and so must the functional requirements.

In a flexible system, only a subset of all FRs must to be satisfied at any given time. For each FR, there may be several candidate DPs to choose from. The “best” DP for an FR is generally not constant. Instead, it depends on the particular subset of FRs that must be satisfied. A similar relationship exists between DPs and PVs. [Suh, 2001]

Educational flexibility can be seen in the adjustment of course offerings in each academic term. If too many seats are offered in a course, then resources are going to waste. If too few seats are offered, then not all students will be educated, reducing both educational quality and customer service. The total set of FRs at the course-level can be seen in the following statement: “educate [n] students in the subject of [x], where n and x are variable. If n is below the minimum enrolment cutoff, then this FR is not in the set that must be satisfied.

The DPs will consist of different courses (e.g. the course catalog), as well as multiple formats for each course. A small course format might involve a discussion style with written tests, whereas a large course format might require a lecture style with electronically graded tests. The number of sections may also be varied to satisfy an FR. An important PV in this system is the type of classroom (e.g. small room vs. auditorium vs. laboratory)

Functional Requirements:	Design Parameters:	Process Variables:
FRi = Educate students on topic i FRi1 = Measure prior knowledge/ abilities FRi2 = Motivate students to learn topic i FRi21 = Provide penalties for failure to learn FRi22 = Provide context for learning about topic i FRi23 = Instill a sense of curiosity about topic i FRi24 = Actively involve students in learning topic i FRi3 = Teach students concepts in topic i FRi31 = Enable auditory learning to understand & synthesize in topic i FRi32 = Enable visual learning to understand & synthesize in topic i FRi33 = Enable independent learning to understand & synthesize in topic i FRi4 = Train students in tasks of topic i FRi5 = Have students practice using topic i FRi6 = Ensure quality of education in topic i FRi61 = Measure student learning FRi62 = Measure student satisfaction	DPi = Unit on topic i DPi1 = Initial assessment DPi2 = Various methods in topic i DPi21 = Academic status or ranking within peer group DPi22 = Statement about context of topic i DPi23 = Everyday examples of topic i DPi24 = The Socratic method DPi3 = Various methods in topic i DPi31 = Conceptual lecture on topic i DPi32 = Visual aides related to topic i DPi33 = Reading assignment on topic i DPi4 = Lab exercise on topic i DPi5 = Problem set related to topic i DPi6 = Measure student ability in topic i DPi61 = Outcomes assessment DPi62 = Student feedback mechanism	PVi = Room, instructor, time, materials PVi1 = Pre-Test PVi2 = Various media in topic i PVi21 = Make students aware of grading policy in syllabus PVi22 = Flow chart / graph of topic i & related topics PVi23 = Images / exhibits of everyday examples of topic i PVi24 = Discussion questions PVi3 = Various media in topic i PVi31 = Presenter educated in topic i PVi32 = Graphs and images on topic i PVi33 = Textbook chapter on topic i PVi4 = Lab equipment PVi5 = Problem set questions PVi6 = Evaluations on topic i PVi61 = Post-Test / Exam PVi62 = Survey

Figure 1a. The FR / DP / PV pairs for a topic being repeated through different goals and methods

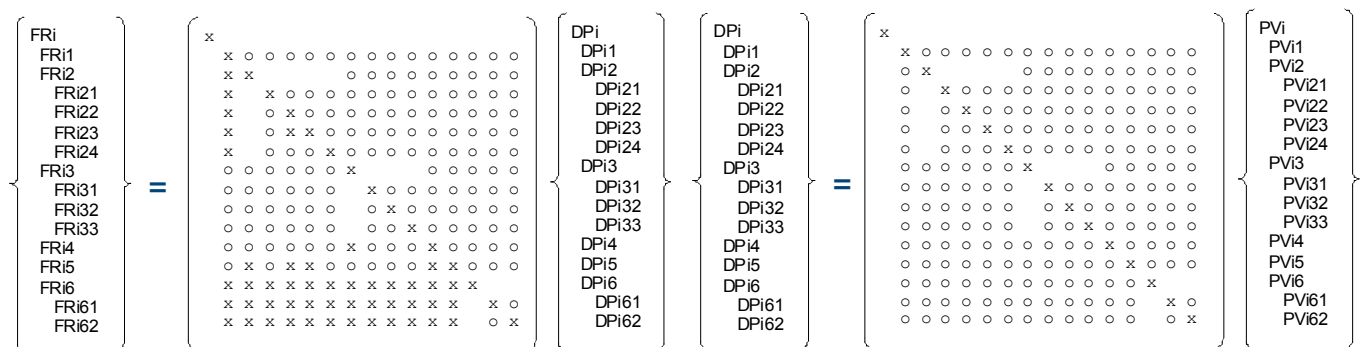

Figure 1b. FR-DP matrix and DP-PV matrix for a topic being repeated through different goals and methods

The course offerings will be affected by the structure of the curriculum design matrix. If one subject is the prerequisite of another (decoupled) and if both have a low enough demand to be offered every-other term, then the offerings should be staggered by term. If two courses are uncoupled, but close together in the matrix, then they should be offered at different times during the same term. The FRs are also connected by the constraints in the process domain. Specifically, resource availability (classrooms and instructors) will limit the configurability of the system. In order to achieve flexibility while managing interdependencies, the curriculum design matrix should be used to design courses as modules with as little coupling as possible.

5 EDUCATION AND THE INFORMATION AXIOM

Not all incoming students and outgoing graduates are the same, even within the same area of study. There is variability in the knowledge and abilities of both the admitted

and the graduating populations. If axiomatic design is applied to an educational curriculum, then the probability of success will be a measure of how successfully the FRs in education have been met: namely, how well students have been educated, and how satisfied the students are with the educational process. The degree of success in education is traditionally quantified through outcomes assessment. Outcomes assessment is performed to determine if the educational outcomes (FRs) of the course or program are being met, and it is often accomplished by using some form of examination (tests, quizzes, etc.). Ideally, a test will be a valid and reliable measure of the degree to which an educational FR has been successfully achieved. In this case, the system range for an existing course can be thought of as the probability distribution of test scores.

The design range in education is the range of acceptable scores. The probability of success is then the percentage of students that receive a “passing” grade. This notion is already well defined for many educational institutions. For example, in some universities, a score of 80% or better is required for

courses within a major of study, and a score of 70% or better is required for outside electives. Note that there is no true upper bound on the design range here. Instead, the maximum of 100% represents the upper end of the range.

Graduation can occur only for students who fall within the design range; that is, a graduate must demonstrate mastery of the concepts and skills that they have learned by fulfilling all course requirements with a minimum grade point average. If the system range of the students is not entirely within the bounds of the design range, then those students who do not lie within the common range cannot graduate. In education, the probability of success is 100% if all students always fall within the design range.

A tolerance in education is the acceptable range of values for a design parameter or process variable, including teachers, students, course materials, and more. This is often a one-sided range, as in the example of a loan officer accepting only customers with a minimum credit score. It is the task of the faculty search committees in a university to establish and enforce the metrics that determine acceptable new faculty. Similarly, it is the task of the admissions department in a university to establish and enforce the metrics that determine acceptable incoming students. These metrics will include things like minimum GPA or SAT scores, and may also have subjective components such as essays. On a smaller scale, individual courses might have tolerances, such as passing grades in prerequisite courses. In grade school, the design range for one grade level is ideally equivalent to the tolerance of the following grade level.

Although upper bounds on educational tolerances do not generally exist, there are some exceptions. The one major exception is when students are able to take advanced standing or advanced placement exams. A college or university will set the lower bound on the tolerance through their admissions standards while the advanced standing/placement exams set the upper bound. If the student falls below the lower bound, they are not admitted. If they fall within the tolerance, they are admitted and take freshmen level courses. If they fall above the upper bound of the tolerance (pass the exam), then they are admitted and take sophomore level courses. This is also analogous to skipping a grade during elementary school.

Like many processes, educational systems will sometimes have a bias. It is the responsibility of the educator to provide education at an appropriate level of detail and difficulty for the students. Ideally, course material will be new, interesting, and challenging, but not impossible for the students to learn. If the course material is too hard, the students may be discouraged and may stop trying to learn. If the course material is too easy, the students may be bored and may stop trying to learn. Thus, it is important even for an educational system for the mean of the design range to correspond to the mean of the system range. In other words, while the upper-bound of an exam may be 100%, the target value may be lower.

Excellent (perfect) exam results for all students may reveal that the course material is too easy or moving too slowly. There is a positive bias in the system and the material should be made more difficult or presented more quickly to correct the situation. Poor (failing) exam results for all students may reveal that the students do not understand the

course material. There is a negative bias in the system and the course material or the teaching methods should be reexamined to determine and correct the problem. Correction could involve a change in the curriculum DPs, or a change in their sequence or pace (e.g. splitting one course into two). Thus, the attempt to minimize or eliminate bias is an important step in the continuous improvement of educational designs. This also highlights another aspect of flexibility in education: individual students will naturally move at different paces, so a curriculum should have the flexibility to move some students faster through advanced courses, and take extra time for those who need it in remedial courses.

When verifying any process, the precision and error inherent in a measurement tool can affect the quality of a measurement. This is also true in education. If the assessment tool (in this case, examination) does not adequately reflect the educational goals, then the results may indicate a bias where none exists. Educators frequently correct this artificial bias by curving examination results or grades. However, it is critical for all educators to be aware of the difference between true bias and artificial bias caused by the assessment tools and be able to recognize the difference.

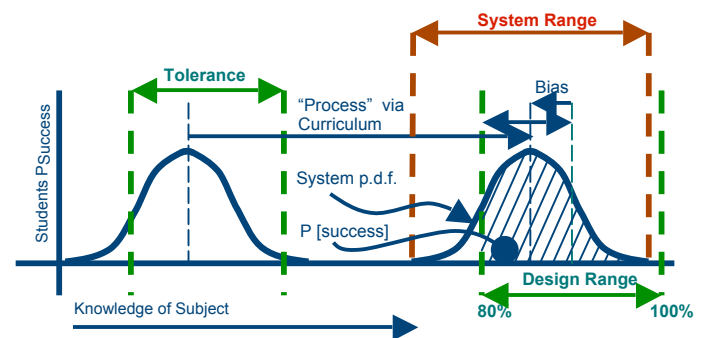

Figure 2. A graphical representation of the axiom as it applies to education

5.1 ROBUSTNESS IN EDUCATION

In traditional axiomatic design theory, a robust design is one that can accommodate large variations in the DPs and PVs and still satisfy the FRs. Consider again the example from Figure 1a. FRi21 is “enable auditory learning to understand & synthesize in topic i” and PVi21 is “instructor educated in topic i.” If the current instructor is replaced by a different instructor, the quality of the lecture and thus the ability of the auditory learning to take place may be radically altered. Thus, this FR/PV pair is not very robust from an axiomatic design view point.

However, FRi22 is “enable visual learning to understand & synthesize in topic i” and PVi22 is “graphs and images on topic i.” Once the graphs and images are generated, they can no longer change and are relatively immune to noise, and environmental and random variance (except for corruption of the image source files) and thus this FR/PV pair is very robust.

Lecturers are an important part of education and should not be dismissed simply because of robustness arguments.

However, the concept of robustness may need to be addressed when course instructors (or other DP and PV related factors) are expected to change on a term-by-term or yearly basis. Also, alternative top-level educational DPs (like a web-based course instead of a lecture-based course) may need to be chosen to fulfill the DPs.

5.2 ROBUSTNESS THROUGH FUNCTIONAL PERIODICITY

Now consider a robust graduate as opposed to a robust curriculum. A robust graduate will be able to solve unforeseen functional requirements. This is one of the goals of educational curricula as it is built in to the definition of education with “the ability to synthesize new ideas.” Another characteristic of robustness is the ability to continue functioning properly over long periods of time. This is clearly an issue in education; after the system range has been measured (via testing), this range is not permanent. Just as mechanical dimensions can change in time with environmental conditions and wear, the knowledge and skills of a student will decrease without proper maintenance in that topic. Unlike mechanical wear, the probability that an education will stay within the design range increases with frequent usage.

As discussed earlier, the maintenance of an educational subject can be handled with repetition. This issue has a deeper meaning in the context of complexity. The fading of knowledge over time is an example of time-dependent combinatorial complexity. It is desirable to transform combinatorial complexity into periodic complexity by introducing functional periodicity. [Suh, 2001] In the case of education, the system range can be re-initialized through a review of the material. This can be systematically implemented through curriculum design. A review of the previous year’s material is often conducted prior to introducing new material. An even more efficient strategy would be to integrate the review into the new material by a strategic selection and sequencing of curriculum DPs. For example, in a mathematically based subject, a set of homework problems might include steps that force the usage of concepts learned in a prerequisite course, thus re-initializing the knowledge of the prerequisite material. Design courses can also be used to apply and integration material learned in previous courses in a new context. This type of review is sometimes inherent in subjects with a decoupled

structure, but it can be managed directly and analytically through the curriculum design matrix and information content.

6 CONCLUSION

Axiomatic Design appears to be well-suited to the design of educational curricula. In this discussion, the groundwork has been laid for a novel analysis of the education process through axiomatic design. Many interesting and potentially useful insights have been revealed by considering some of the more detailed implications of the independence and information axioms as they apply to education. It is believed that such a systematic approach can provide a powerful means of designing and organizing efficient, effective, and robust curricula to best meet the needs of students. One of the strengths of axiomatic design is its ability to help guide designers directly toward good designs without costly trial and error. This notion is especially important in education, where “trial and error” can turn into “trial by fire” for those being educated. The methodology outlined requires further development, as many subtleties remain unclear. The authors are hoping to conduct more detailed case studies in this area in the future.

7 REFERENCES

- [1] Suh, Nam P, *Axiomatic Design: Advances and Applications*, Oxford (2001).
- [2] Tate D., Lu, Y. “Strategies for Axiomatic Design Education.” *Proceedings of ICAD2004 The Third International Conference on Axiomatic Design* Seoul, Korea, June 21-24, 2004.
- [3] Tate D., “Design and Creation of Web-based Educational Materials for Teaching Axiomatic Design”, *Proceedings of the Eight World Conference on Integrated Design and Process Technology*, Society for Design and Process Science, Beijing, China, June 13-17, 2005.
- [4] *The American Heritage Dictionary of the English Language*, 4th Ed., Boston (2004).